

**Errata 3 to CSSBI B15-07:  
Snow, Wind and Earthquake Load Design Criteria for Steel  
Building System**  
March 2009

NOTE: This Errata includes Errata 1 dated February 2007 as well Errata 2 dated October 2008.

**Errata 3**

Page 11

**FIGURE A1(A): SHAPE FACTOR,  $C_a$ , FOR SINGLE SLOPE ROOFS**

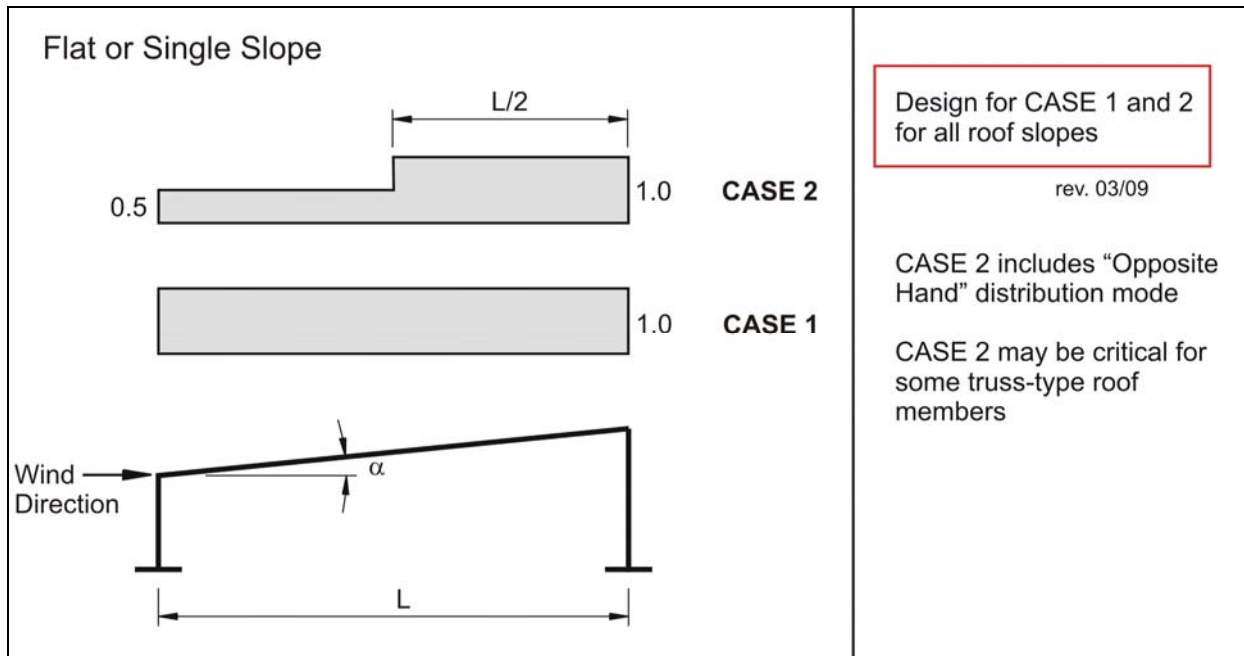

Page 9

**A6 – Illustrative Example #3**

*Step 1: Determine the basic roof snow load factor,  $C_b$*

The upper level roof dimensions are:  $l = 50$  m,  $w = 40$  m

$$l_c = 2w - w^2/l = (2)(40) - (40)^2/(50) = 48$$

Since  $l_c = 48 < 200$ , with  $C_w = 0.75$ , there is no increase in the basic roof snow load factor.

$$\therefore C_b = 0.8$$

## CSSBI B15-07, Errata 2 (October 2008)

Please replace the drawing in Figure B10 with the figure below. The change is in the direction of the applied loads for  $p_3$  and  $p_4$  in the lower figure.

Page 30

**TABLE B10: Design Case 2 Frame Loading**

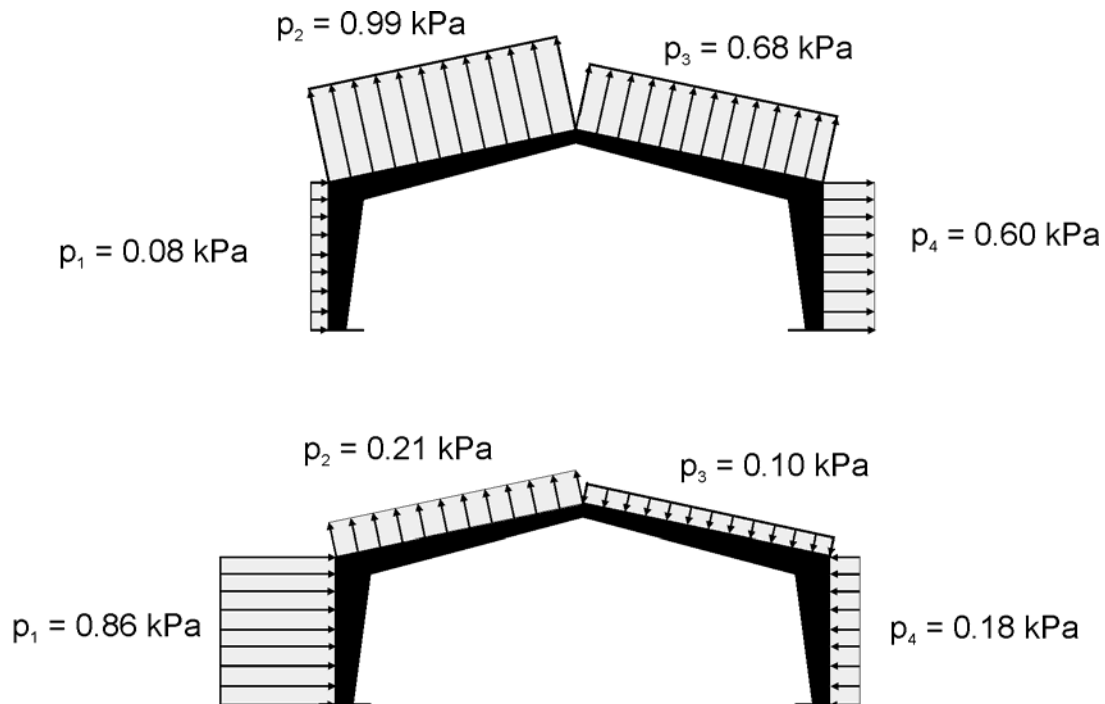

## CSSBI B15-07, Errata 1 (February 2007)

Please note the corrections to Table B2(A) highlighted below.

Page 31

### TABLE B2: ROOF CLADDING

B2(A) FOR ROOF SLOPES OF 7° OR LESS

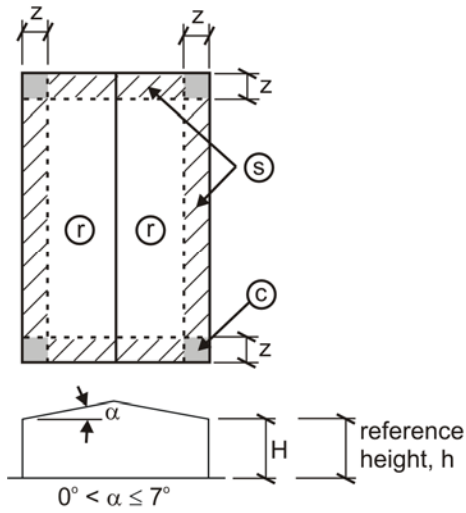

Building Category		r	s	c	
	$C_p C_g$	+0.5 -1.8	+0.5 -2.5	+0.5 -5.4	Non-composite interior and exterior sheets
(3)	$C_{pi} C_{gi}$	$\pm 1.4$	$\pm 1.4$	$\pm 1.4$	
(2)	$C_{pi} C_{gi}$	+0.6 -0.9	+0.6 -0.9	+0.6 -0.9	
(1)	$C_{pi} C_{gi}$	+0.0 -0.3	+0.0 -0.3	+0.0 -0.3	Single sheet or composite interior plus exterior sheet
(3)	$C_p C_g + C_{pi} C_{gi}$	+1.9 -3.2	+1.9 -3.9	+1.9 -6.8	
(2)	$C_p C_g + C_{pi} C_{gi}$	<b>+1.4</b> <b>-2.4</b>	<b>+1.4</b> <b>-3.1</b>	<b>+1.4</b> <b>-6.0</b>	
(1)	$C_p C_g + C_{pi} C_{gi}$	<b>+0.8</b> <b>-1.8</b>	<b>+0.8</b> <b>-2.5</b>	<b>+0.8</b> <b>-5.4</b>	